



OPERATING MANUAL



Please read this manual carefully before operating!

Table of Contents

Contents	Page
1. Introduction.....	3
2. Important Safety Instructions.....	3
3. Installation Safeguards.....	3
4. General Safeguards.....	5
5. Operating Conditions.....	6
6. Operating Precautions.....	6
7. Installation.....	7
8. System Components.....	8
9. Control Panel (Front)	9
10. Power Panel (Rear)	9
11. Safety Shield	10
12. Feed Table	11
13. Roller Gap Adjustment	12
14. Temperature Display.....	12
15. Operation.....	13
16. Roller Cleaning Function	15
17. Auto Sleep Function	15
18. Motor Switch Safety Function	15
19. Heat Sensor Safety Function	16
20. Loading Film Rolls	16
21. Using 2 ¼” Film core adaptors	19
22. Threading Film	21
23. Adjusting Brake Tension	22
24. Troubleshooting	23
25. Specifications	24
26. Warranty	25

1. Introduction

Thank you for choosing the Phoenix 2700 DHP laminator. It has been designed and manufactured to provide years of continuous service. Please read this manual thoroughly before operating. Please inspect the box and the laminator for shipping damage. Damage should be brought to the attention of the delivering carrier immediately.

We reserve the right to make changes to this publication and to the products described in it without notice. The details given in this manual are based on the most recent information available to us. They may be subject to change in the future. We retain the right to make changes to the construction or the design of our products without accepting any responsibility for modifying earlier versions.

WARNING! Any unauthorized changes or modifications to this unit without our prior written approval will void the user's warranty and will transfer health and safety obligations to the end user.



CAUTION! Please pay attention to all passages with these symbols. This information is vital to preventing user injury and/or damage to the unit. Failure to follow this information could void the user's warranties and transfer all safety obligations to the user.

2. Important Safety Instructions

In this operating manual, you will find important safety messages regarding the product. Read these instructions carefully, failure to comply with the following safety procedures could result in serious injury.

WARNING Do not attempt to service or repair the laminator. Only authorized maintenance and service technicians should make repairs.



WARNING Do not connect the laminator to an electrical supply or attempt to operate the laminator until you have completely read these instructions. Maintain these instructions in a convenient location for future reference.

WARNING To guard against injury, the following safety precautions must be observed in the installation and use of the laminator.

WARNING **Ensure the safety shield is in place before operating the Laminator.**
Operating without the safety shield can cause serious injury.

3. Installation Safeguards

- Shipping damage should be brought to the immediate attention of the delivering carrier.
- Avoid locating the laminator near sources of heat or cold. Avoid locating the laminator in the direct path of forced, heated or cooled air.
- The receptacle must be located near the equipment and easily accessible.
-  Connect the power cord provided with the laminator to a suitably grounded outlet only. This machine must have reliable earth ground wire to ensure the safety of the machine during operations.

- Contact an electrician should the power cord provided with the laminator not match the receptacles at your location.
-  Ensure that the voltages of the power supply you are using match the rated working voltages before operations. Do not use incorrect power supply.
-  Do not use damaged wires or sockets. If abnormal conditions occur, switch off the power supply first.
-  Only a licensed electrician should install wiring and outlet for the laminator.
- Do not defeat, disable, or remove electrical and mechanical safety equipment such as interlocks, shields and guards.

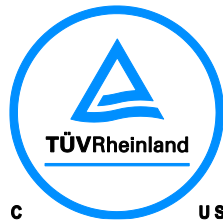



NOTE: This equipment has been tested and found to comply with the limits for a Class B digital device, pursuant to part 15 of the FCC Rules. These limits are designed to provide reasonable protection against harmful interference in a residential installation. This equipment generates, uses and can radiate radio frequency energy and, if not installed and used in accordance with the instructions, may cause harmful interference to radio communications. However, there is no guarantee that interference will not occur in a particular installation. If this equipment does cause harmful interference to radio or television reception, which can be determined by turning the equipment off and on, the user is encouraged to try to correct the interference by one or more of the following measures:

- Reorient or relocate the receiving antenna.
- Increase the separation between the equipment and receiver.
- Connect the equipment into an outlet on a circuit different from that to which the receiver is connected.
- Consult the dealer or an experienced radio/TV technician for help.

Changes or modifications not expressly approved by the party responsible for compliance could void the user's cTUVus safety certification.

4. General Safeguards

- Keep hands, long hair, loose clothing, and articles such as neckties away from rollers to avoid entanglement and entrapment. The rollers have pinch points that can trap body parts or clothing and cause serious injury.
- Do not use the machine for purposes other than lamination, otherwise damages to the machine or accidents may occur.
- Keep out of reach of children.
- Keep flammable and wet objects away from the machine.
- Do not use flammable sprays or materials when cleaning the machine.
- Do not leave the machine unattended during operations.
- Do not put burrs, sharp blade or rigid materials in between the two rubber rollers.
- Do not attempt to laminate items that exceed total recommended material thickness of the unit.
- Do not place foreign object inside the machine.
- Do not cut adhesive films directly on the surface of the rollers to avoid damaging the rubber coating.
- Shut down the machine after laminating to avoid misusing this machine by others.
- Turn off the power switch and unplug the power cord before moving the machine.
- Note the locations of foot wheels while moving or operating this machine to avoid injuries to your feet.
-  Disconnect from the power supply before repair or maintenance.
-  Disconnect from the power supply when the machine is not in use for a long time.
- When the machine lies idle for a long period of time, raise the top rubber roller to avoid the damage to the rubber surface.
- Perform only the routine maintenance procedures referred to in these instructions.

5. Operating Conditions

- Environment requirements:
 - Ambient temperature: 50° F - 104° F
 - Humidity: 30%—80%; Ideal humidity: 55%
- Due to the static on film rolls, you should try to keep the environment clean.
- Provide enough space around machine to ensure the safe and effective operation. The minimum area covered is 8 ft. x 10 ft.
- Do not directly cut the films on the surfaces of the rubber rollers to avoid damages to the rollers.
- Do not put burrs, sharp knives or extra thick and hard materials in between the rollers. Do not leave objects like tools, rulers, knives, etc on the working panels or the side cabinets to avoid there being rolled into the machine accidentally and damaging the rollers.
- For repairs and replacements, please contact your local distributor. Unauthorized repairs and dismantling will affect future maintenances of the machines.



***Warning: Do not keep the machine in direct sunshine or near it.
Do not keep the machine in dusty areas or places with strong vibrations.***

6. Operating Precautions

- The following objects should not be subject to lamination:
 - Volatile substances or any thermal-sensitive substances (e.g. Vinyl chloride).
 - Valuable, unique and unrecoverable objects.
 - Objects subject to change of color and nature attributable to heat (e.g. thermal sensitive paper, crayons etc.).
- Improper operation may lead to lamination failure, therefore, when using this laminator, one must choose the correct relations between the machine speed, laminating film thickness, and the material to be laminated.
- The guiding principles of lamination are:
 - The thicker the laminating film and material to be laminated, the slower the machine speed
 - Conversely, the thinner the laminating film and material to be laminated, the higher the speed.
- For best results, try similar material to find the suitable temperature and speed relationship before performing lamination on final product.
- Never leave the operating machine unattended.



Caution: Safety Shield and Feed Tray must be in their proper position for operation.

7. Installation

1. Lift machine straight up and out of the box.
2. Set machine on sturdy table or optional machine stand.
3. Remove plastic cover and operating manual.
4. Remove the feed tray and safety shield.

NOTE: Remove all parts from shipping crate and boxes. Inspect parts and the machine carefully. Any missing parts should be reported to the shipper upon receipt of shipment.



8. System Components

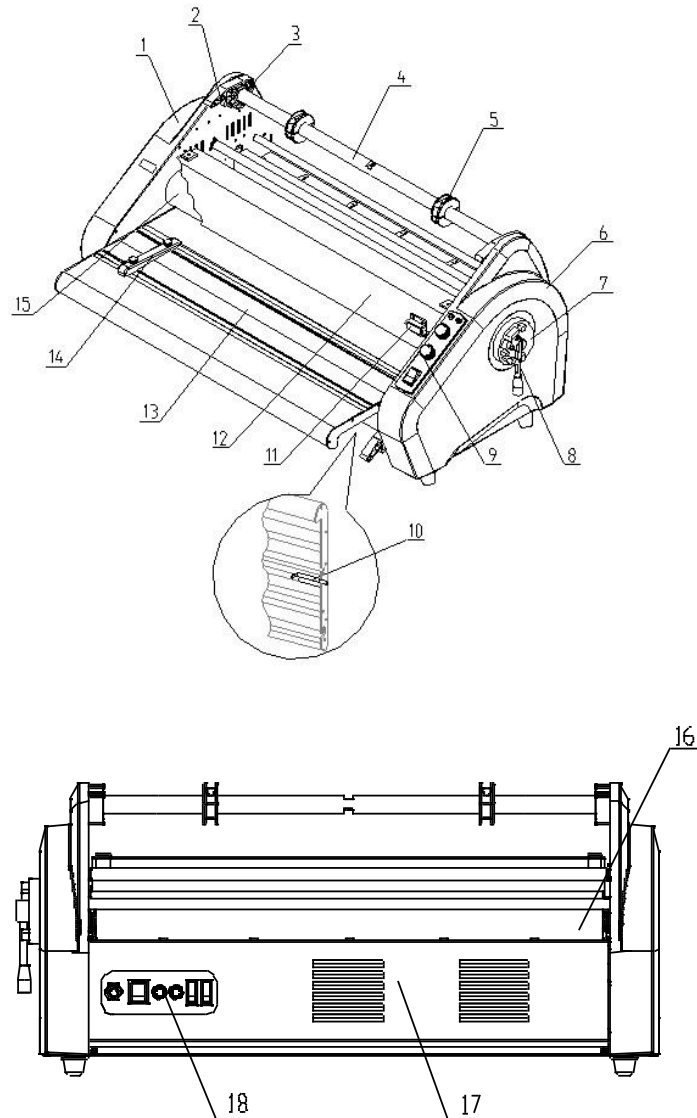

- | | |
|--------------------------|--------------------------------|
| 1. Left Side Cabinet | 10. Feed Table safety latch |
| 2. Tension Adjustment | 11. Safety Shield safety latch |
| 3. Supply Roll Bracket | 12. Safety Shield |
| 4. Supply Shaft | 13. Feed Table |
| 5. 2 1/4" Core adaptor | 14. Side Guide |
| 6. Right Side Cabinet | 15. Top Roller |
| 7. Roller Gap Adjustment | 16. Bottom Roller |
| 8. Roller Gap Handle | 17. Back Panel |
| 9. Control Panel | 18. Rear Power Panel |

9. Control Panel (Front)

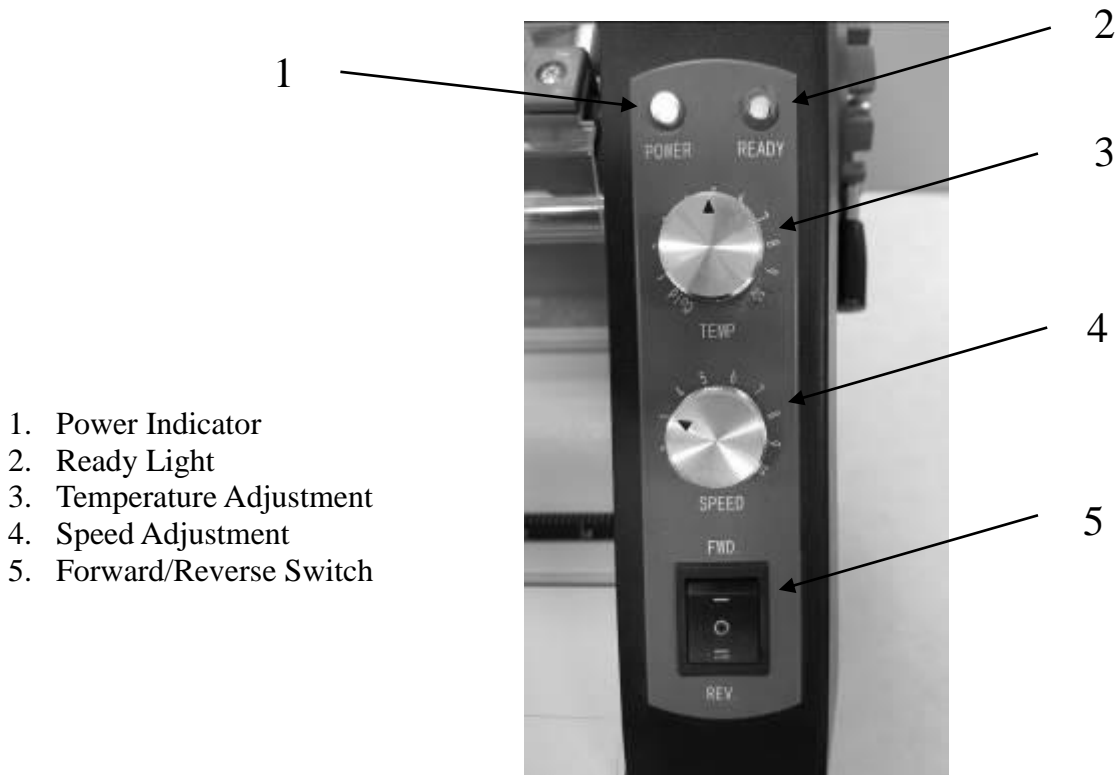

1. Power Indicator
2. Ready Light
3. Temperature Adjustment
4. Speed Adjustment
5. Forward/Reverse Switch

10. Power Panel (Rear)

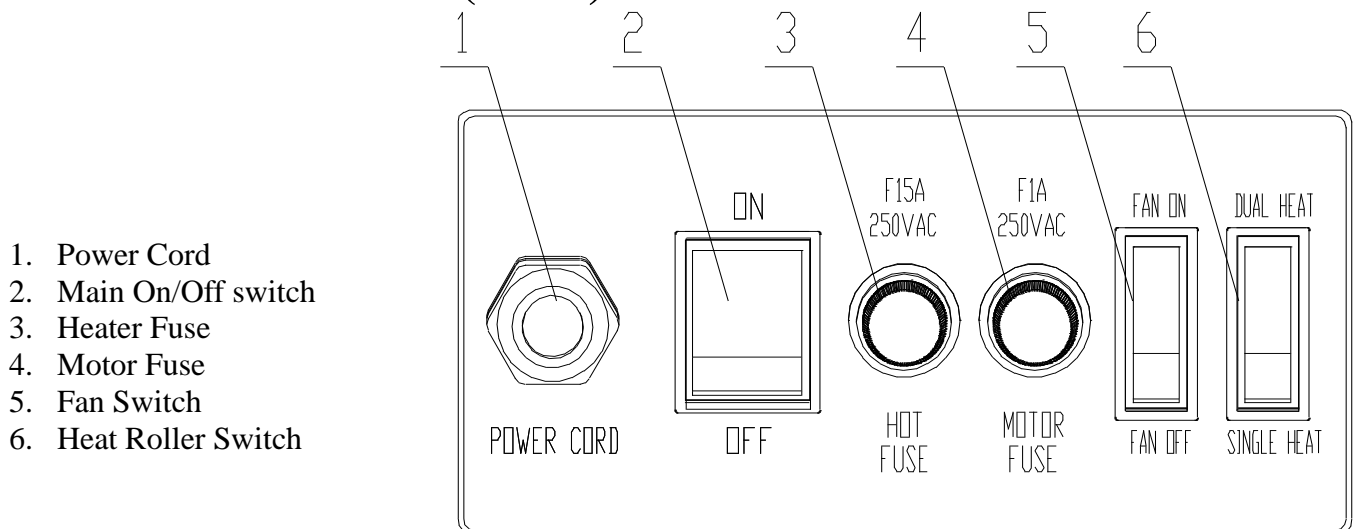

1. Power Cord
2. Main On/Off switch
3. Heater Fuse
4. Motor Fuse
5. Fan Switch
6. Heat Roller Switch

11. Safety Shield

1. Insert left side of shield with spring pin into positioning holes on left side frame.
2. Insert right side pin into positioning hole on right side frame.
3. Lower safety shield onto side support pins.

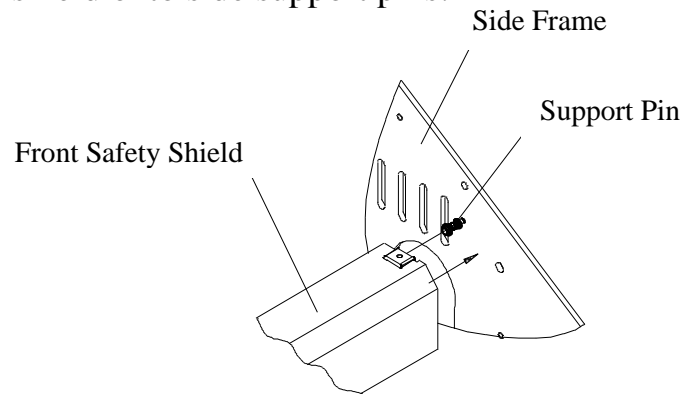

4. Slide Safety Shield latch to the right and locked position to engage the safety interlock switch
5. To release the latch, press the Red button on the lock

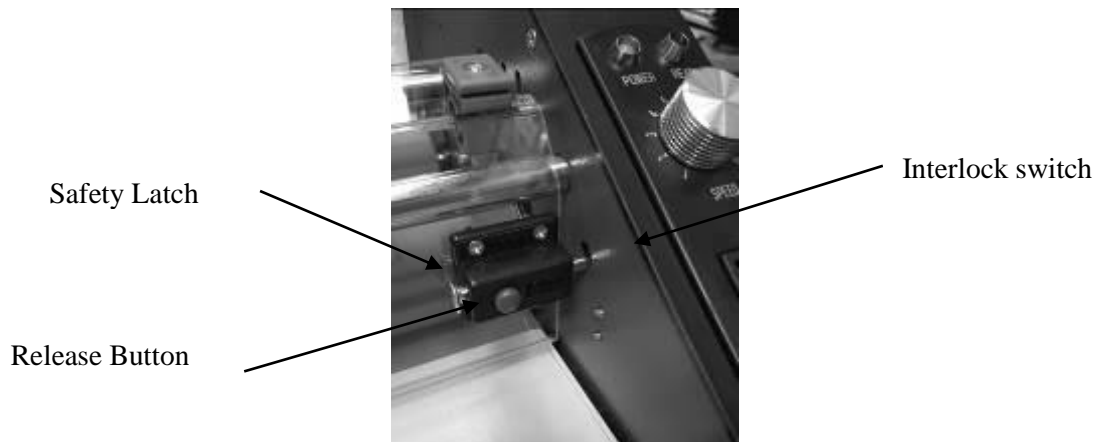

Warning: Ensure the safety shield is in place before operating the Laminator. Operating without the safety shield can cause serious injury.

Note: The laminator will operate only when the Safety Shield and Feed Table are in the fully locked position. Both the interlocking switches must be activated for power to be supplied to the motor

12. Feed Table

1. Rotate Safety Shield to full upright position
2. Insert Feed table onto back two positioning pins on both side frames
3. Retract Feed table safety latch located under right side of table

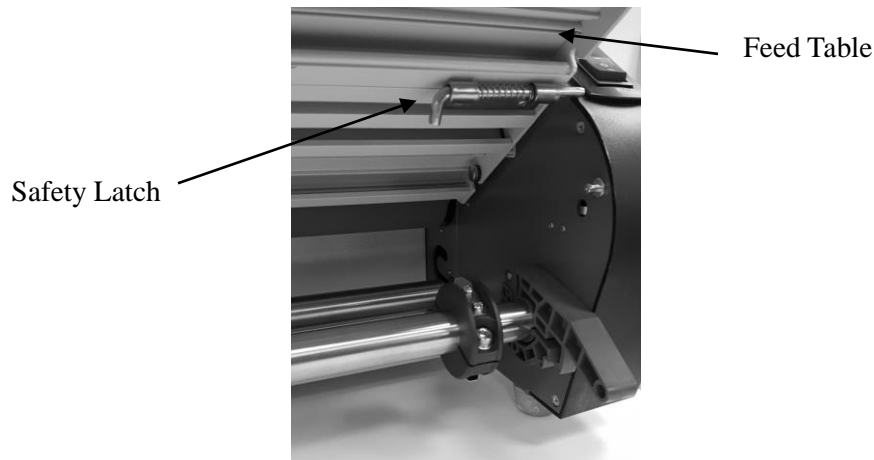

4. Lower Feed table onto the front side support pins on both side frames
5. Slide Feed Table safety latch to the right and locked position to engage the safety interlock switch
6. To remove Feed Table, retract safety latch, lift front edge, then back edge away from support pins, then lift away from machine

Note: The laminator will operate only when the Safety Shield and Feed Table are in the fully locked position. Both the interlocking switches must be activated for power to be supplied to the motor

13. Roller Gap Adjustment

1. Laminate Position
2. 1/16" Gap
3. 1/8" Gap
4. 3/16" Gap
5. 1/4" Gap
6. Open/Full Gap

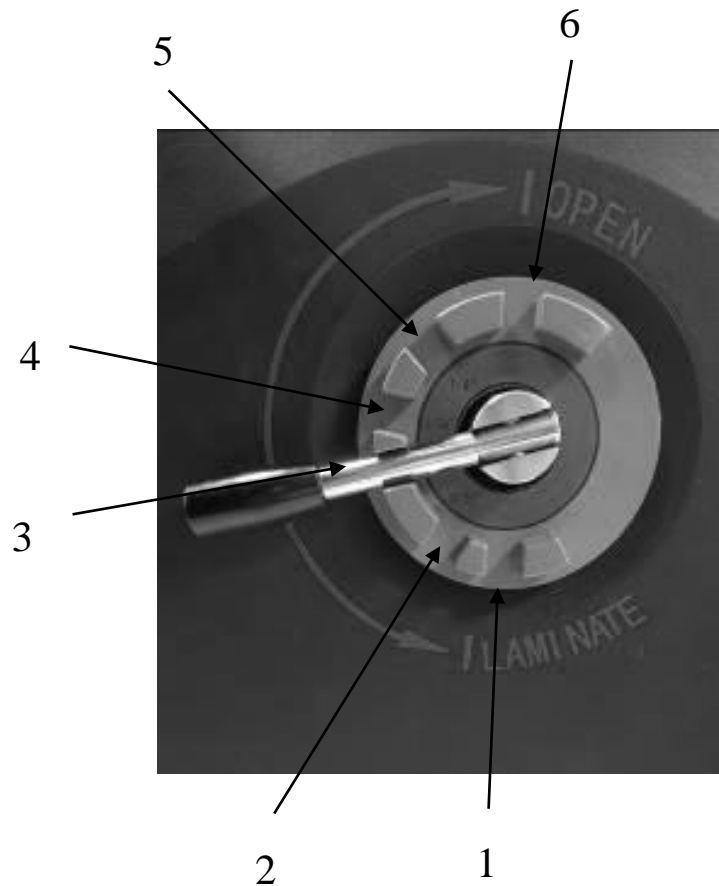

14. Temperature Display

- LCD temperature display is located on the left – front side cover.
- Temperature is measured near the center of the top roller only.



15. Operation

1. General Operation

- Connect the power cord provided with the laminator to a suitably grounded outlet only.
 - a) Contact an electrician should the power cord provided with the laminator not match the receptacles at your location.
 - b) Ensure that the voltages of the power supply you are using match the rated working voltages before operations. Do not use incorrect power supply.
- Turn the main ON/Off switch on the Rear Power Panel to the ON position, the BLUE power indicator lamp on the control panel will illuminate solid.
- Rotate the Temp knob to the desired temperature setting
 - a) Three slow audible beeps from the circuit board indicates the heaters have been turned on
 - b) Two beeps indicate one or both safety interlock switches are not in the locked position, so heaters are not on (See # 11 Safety Shield and # 12 Feed Table)
 - c) Three repeating beeps and flashing power light indicates the heat sensor is blocked. (See #17 Heat Sensor Safety Feature)
- The green ready light on the control panel will illuminate when the rollers have reached the temperature set point selected.
- The forward/reverse switch on the control panel is used to control THREE (3) motor conditions:
 - When the switch is in the FORWARD position, the machine runs forward.
 - When the switch is in the MIDDLE position, the machine stops running, but the heaters remain on.
 - When the switch is in at the REVERSE position, the machine runs in reverse direction.
- Set the Speed knob to the appropriate setting for the material to laminate

2. Thermal Laminating (Encapsulation)

- Turn heater switch on rear panel to DUAL position to activate both heaters.
- Rotate roller gap adjustment handle to down LAMINATE position.
- Turn temperature dial clockwise to desired temperature setting.
- Turn speed dial clockwise to desired speed setting.
- If using 5 or 10 mil films, turn fan switch on rear panel to ON position.

- Recommended settings below are for High temperature (210 F activation) 1.5 and 3 mil film and Low temperature (185 F activation) 5.0 and 10 mil film:

Film Thickness	Dial Settings		
	Temperature	Speed	Approx. Temp display
1.5 mil	7	3	260° F
3.0 mil	7	2	260° F
5.0 mil with Fans ON	6	1.5	234° F
10 mil with Fans ON	6	1	234° F

3. Pouch board mounting

- Turn heater switch on rear panel to SINGLE position to turn off bottom heater.
(Allow 20-25 minutes for bottom roller to cool down)
- Rotate roller gap adjustment handle to position matching board thickness.
- Turn temperature dial clockwise to desired temperature setting.
- Turn speed dial clockwise to desired speed setting.
- Recommended settings for pouch boards is Temperature setting 10 and Speed setting 1.5.

NOTE:

- Recommended settings are starting points only and should be adjusted according to quality of output achieved.
- Excess heat may damage the printed image or cause waves. Insufficient heat may result in delamination.
- Thinner stocks can be run faster, and thicker stocks or heavy ink coverage should be run slower.
- Some stocks and ink-sets cannot be effectively laminated with thermal films. Compatibility testing is recommended before laminating long runs.



WARNING: Ensure the safety shield is in place before operating the Laminator. Operating without the safety shield can cause serious injury.

16. Roller Cleaning Function

1. First remove both the Safety Shield and Feed Table
2. Turn main power ON/OFF switch to OFF position
3. Press and hold the Reverse switch while turning the ON/OFF switch back to ON
4. Release the Reverse switch
 - a. You will hear two audible beeps and the Power and Ready lights will alternate on and off indicating the Cleaning mode
5. Use the reverse switch to rotate the rollers for cleaning
6. To return to normal operation, turn the main ON/OFF switch to OFF
7. Return Safety Shield and Feed Table to locked position

17. Stand By and Auto Sleep Functions

1. If the motor has been idle for Three (3) hours without running, the machine will go into STAND BY mode. The temperature drops to 176° F and the ready light flashes.
 - a. To resume operation, press the MOTOR switch to the FWD position, then back to the middle OFF position.
 - b. Allow machine to reheat to proper temperature and Ready light to illuminate solid.
2. If the motor has been idle for four (4) hours without running, the machine will go into SLEEP mode, and the heaters are turned off.
 - a. To resume operation, press the ON/OFF switch to OFF position, then back to ON and allow the ready light to come on.

18. Motor Switch Safety feature

1. Should the main ON/OFF switch be turned to OFF while the motor switch is in FWD position, the motor must be reset to resume operation.
2. To reset the motor, turn the main ON/OFF switch to the ON position, then turn the motor switch to the off or "0" position, then to FWD when ready to operate.

19. Heat Sensor Safety Feature

1. Should the heat sensor located on the back side of the top heat roller become blocked, the motor and heater will stop
2. The Power light will flash, and you will hear three fast repeating audible beeps
3. Clear away any paper or film between the sensor and the roller from rear of the machine

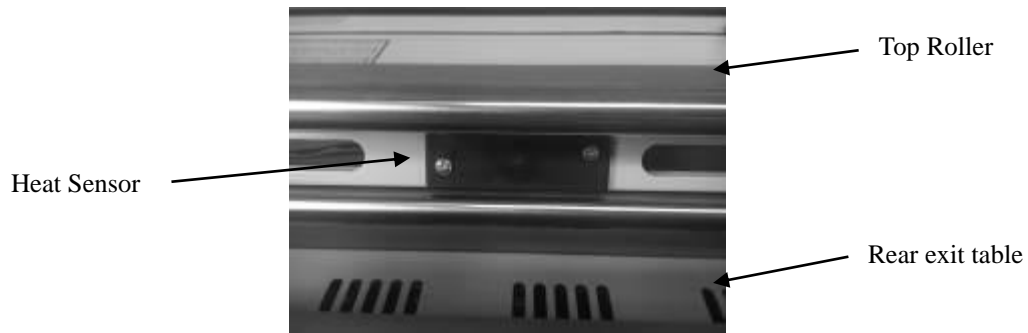

4. To reset the sensor, turn the motor Forward/Reverse switch to neutral or “O” position and the main ON/OFF switch to OFF, then back to ON
 - a. You should hear three slow beeps indicating the sensor has been cleared

20. Loading Film rolls

1. Determine whether your film is on 1” or 2 ¼” diameter cores
2. Select to use the 1” core clip or 2 ¼” core adaptor for your film
 - a. 1” core clip is mounted in the middle of each supply shaft
 - b. If using 1” core film, loosen the two (2) adaptor screws on each 2 ¼” core adaptor and slide them off the film shafts

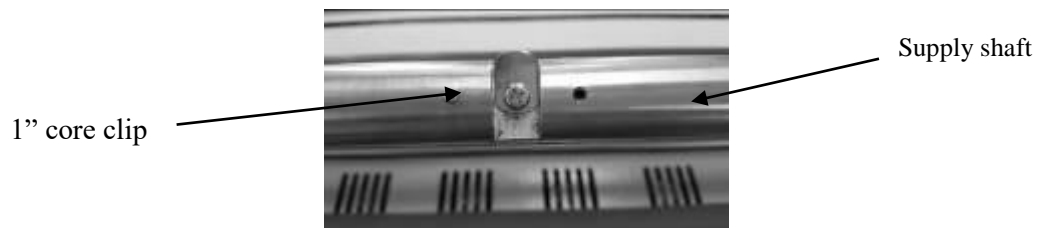

- c. Two - 2 1/4" core adaptors slid onto each supply shaft
(See section #21 Using 2 1/4" core adaptors)

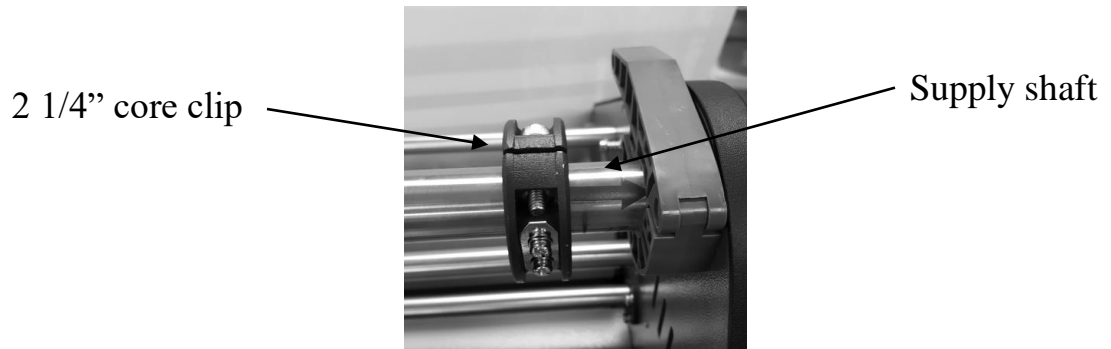

3. Determine whether your film is POLY IN or POLY OUT style
a. Side "A" has the adhesive (Poly).

POLY- IN

POLY- OUT

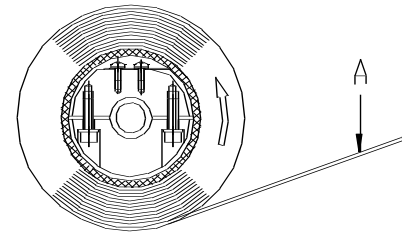

4. Place the supply shafts onto the shaft brackets with the arrows on the shaft matching the arrows on the left and right-side frames.

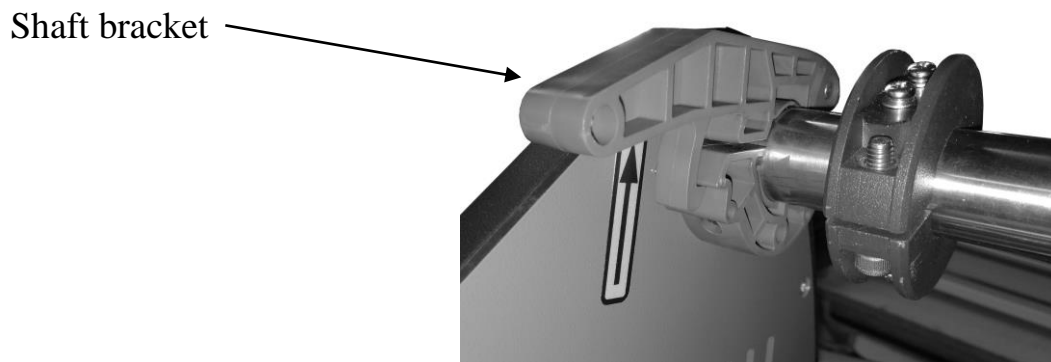

5. Remove each supply shaft, while aligning the arrow on the shaft with the arrow on the machine side frame, slide the film roll onto the shafts with the film web coming off the bottom or the top of the roll depending on the poly direction of the film.
 - a. POLY-IN film comes off the BOTTOM of the roll
 - b. POLY-OUT film comes off the TOP of the roll.

Note: Twisting the film roll in the direction of the core clip or with the core clip, will help slide the roll onto the core adaptors.

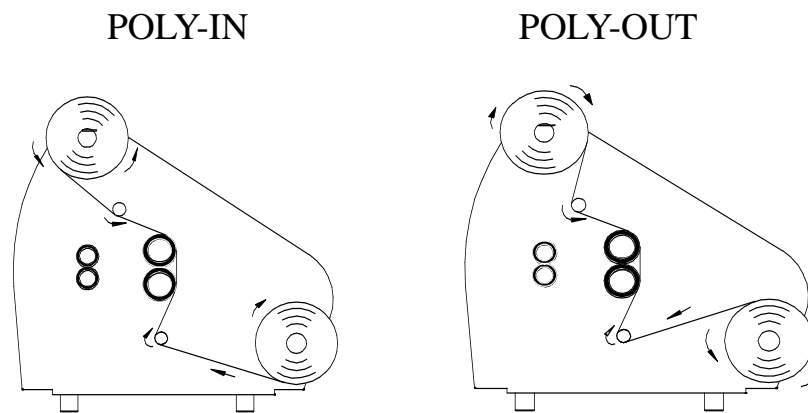

21. Using 2 ¼” Film core adaptors

1. Place the supply shafts onto the shaft brackets with the arrows on the shaft matching the arrows on the left and right-side frames.

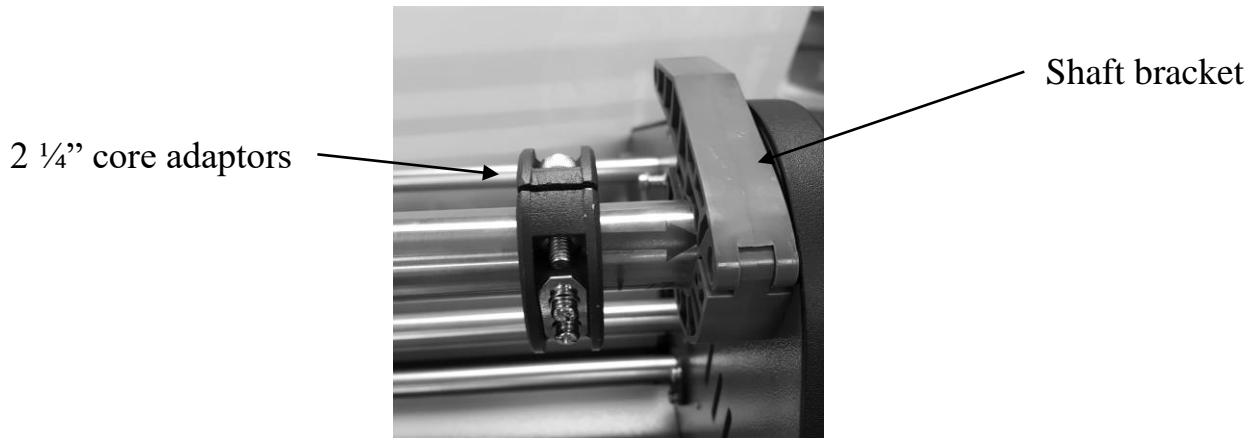

2. If using POLY-IN film:
 - c. Select Four (4) 2 ¼” core adaptors
 - d. Slide Two (2) core adaptors onto the TOP shaft with the core clips pointing toward the FRONT of the machine when the clips are on TOP and the shafts are in place.
 - e. Slide Two (2) core adaptors onto the BOTTOM shaft with the core clips pointing toward the REAR of the machine when the clips are on TOP and the shafts are in place.

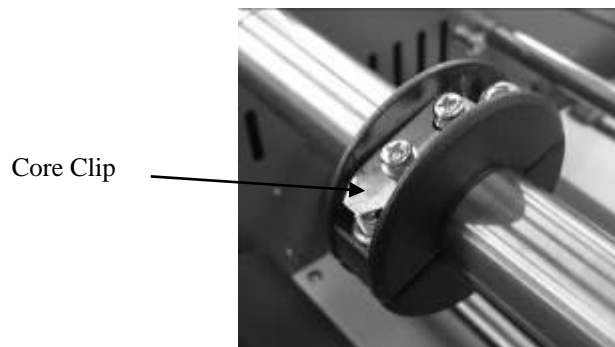

3. If using POLY-OUT film
 - f. Select Four (4) 2 ¼" core adaptors
 - g. Slide Two (2) core adaptors onto the TOP shaft with the core clips pointing toward the REAR of the machine when the clips are on TOP and the shafts are in place.
 - h. Slide Two (2) core adaptors onto the BOTTOM shaft with the core clips pointing toward the FRONT of the machine when the clips are on TOP and the shafts are in place.

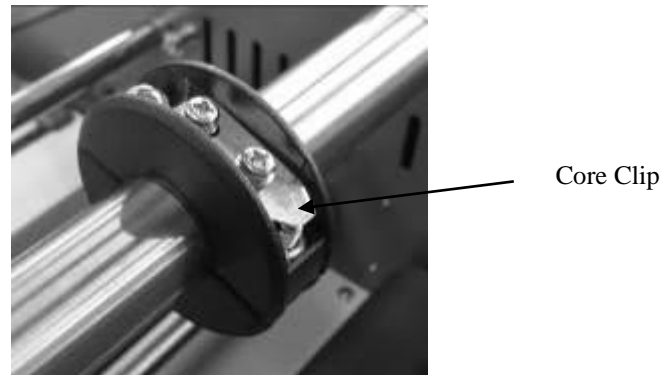

4. Position each core adaptor 50 mm (2 inches) inside the edge of the film roll width as noted on the supply shaft.

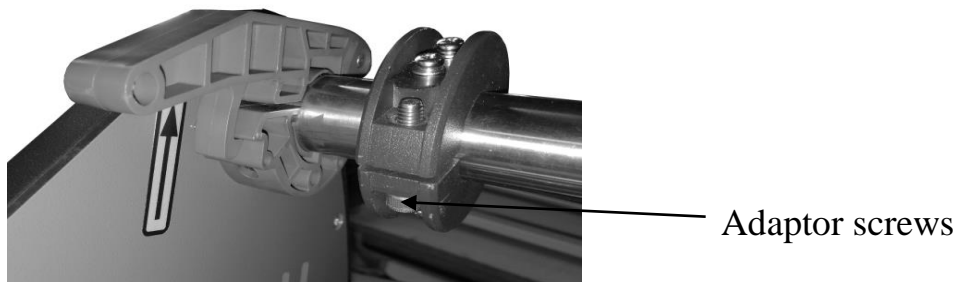

5. Tighten the two (2) core adaptor screws on each core adaptor.

22. Threading Film

1. Raise the gap adjustment handle to the up "OPEN" position.



2. Pull the top film web under the top idler bar and drape over the two heat rollers.
3. Move the bottom idler bar to the down position.
4. Pull the bottom film web under the bottom idler bar, then up over the two rollers sticking it to the top film web.
5. Return the bottom idler bar to the up position in the idler bar channel.

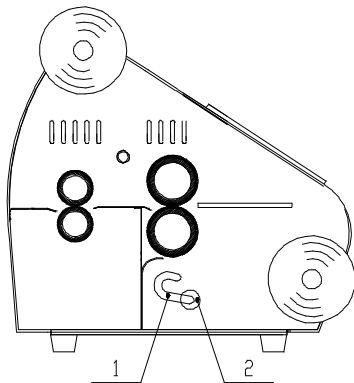

1. Idler Bar Channel
2. Bottom Idler Bar

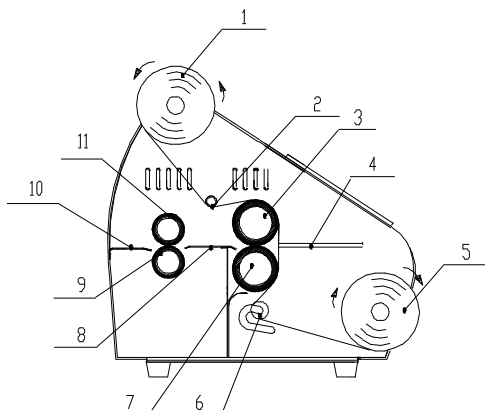

1. Upper Film Roll
2. Top Idler Bar
3. Top Heat Roller
4. Feed Table
5. Lower Film Roll
6. Bottom Idler Bar
7. Bottom Heat Roller
8. Cooling Deck
9. Bottom Pull Roller
10. Exit Tray
11. Top Pull Roller

6. Push the two film webs between the front rollers using a treading card or piece of thin cardboard.
7. Return the gap adjustment handle down to the “Laminate” position.
8. Use the motor switch on the control panel to advance the film web through the front rollers and between the rear pull rollers, until the threading card can be cut from the web at the rear of the machine.
9. Return the feed tray into position.
10. Return the safety shield into position.

Note: The film should be smooth and taught to the surface of the heat roller. If the film is not tight enough, adjust the brake tension on both sides of both top and bottom film rolls.

23. Adjusting Brake Tension

1. To remove wrinkles in the film web, tighten the brake adjustment on each film supply shaft using the supplied Allen wrench.
 - a. Clockwise to increase brake tension.
 - b. Counterclockwise to loosen brake tension.

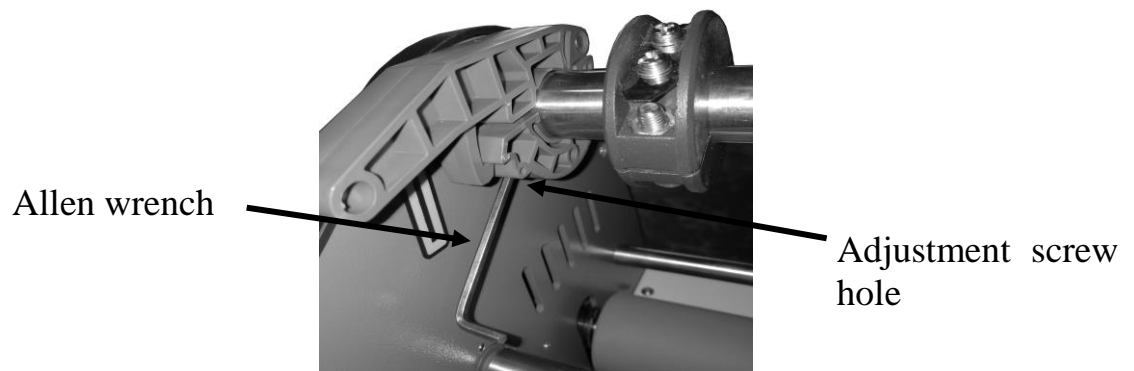

Note: Do not over tighten the brake tension. Apply only enough tension to the film web to smoothen out wrinkleless before they enter the laminating nip point and appear on the printed material.

24. Troubleshooting

Problems	Causes	Solutions
Machine does not turn on	<ol style="list-style-type: none"> 1. No power supply 2. Main power switch is OFF 3. Blown motor fuse 4. Motor has failed 5. Machine is in Sleep mode 	<ol style="list-style-type: none"> 1. Plug in power cord 2. Move power switch to ON position 3. Replace fuse on rear panel 4. Change the electric motor 5. Rotate Reset switch on rear panel
Heaters do not come on	<ol style="list-style-type: none"> 1. Heat switch not on 2. Safety shield or Feed Table not in place with safety interlock 	<ol style="list-style-type: none"> 1. Move heat switch to ON position 2. Insure safety latches are in place
Ready light does not come on	<ol style="list-style-type: none"> 1. Rollers not hot enough 2. Heaters are not turned on 	<ol style="list-style-type: none"> 1. Warm up time is 20-25 minutes 2. Move heat switch to ON position
Poor film adhesion/cloudy prints	<ol style="list-style-type: none"> 1. Nip roller pressure too low 2. Operating too fast 	<ol style="list-style-type: none"> 1. Place gap handle in down position 2. Turn speed dial to slower speed
Bubbles in film around print	<ol style="list-style-type: none"> 1. Operating too slow 	<ol style="list-style-type: none"> 1. Turn speed dial to faster speed
Film supply roll gets loose during operation	<ol style="list-style-type: none"> 1. Not enough brake tension supply 	<ol style="list-style-type: none"> 1. Increase brake tension on supply roll
Lamination output is curled	<ol style="list-style-type: none"> 1. Sheet is curled upward 2. Sheet is curled downward 	<ol style="list-style-type: none"> 1. Reduce top roll tension 2. Reduce bottom roll tension
Two audible beeps when machine is turned ON, machine will not heat up	A Safety interlock switch is not in position	Check both Safety Shield and Feed Table interlocks (See sections 11 and 12)
Power light flashing and 3 audible beeps	Heat sensor is blocked	Clear sensor then turn motor off then Main power off then on (See section 19)
Ready light flashing	Machine is in Standby Mode	Turn motor to FWD then off, allow machine to heat up (See section 15)
Power is ON but not lights	Machine is in Sleep Mode	Turn power switch OFF then ON, allow machine to heat up (See section 15)
Main power switch if OFF and motor is in FWD position	Machine was turned OFF while motor was running	Turn power to ON and motor to OFF then ON (See section 16)
Power and ready lights are both flashing	Machine is in Clean mode	Turn Power to ON and motor to OFF then ON

25. Specifications

Description	Phoenix 2700 DHP
Laminating Width	27"
Roller Diameter	2.5"
Roller Gap	1/16", 1/8", 3/16", 1/4"
Temperature	176° F - 300° F (variable temperature)
Warmup Time	20 – 25 min.
Heating Method	Quartz tube
Laminating Speed	1.6 to 10 Ft/min (variable)
Film Unwinds	Top and bottom
Film Core Size	1" and 2 ¼"
Film Thickness	1.5 - 10 mil
Power Supply	120 v 12 amp
Power Consumption	1440 W
Net Weight	120 lbs.
Dimensions	36.5" x 22.5" x 16"
Shipping Weight	132 lbs.
Shipping Dimensions	39" x 20" x 22"

26. Limited Warranty

The Manufacturer warrants to the original Consumer purchaser that each new PHOENIX Laminator which proves defective in materials or workmanship within the applicable warranty period will be repaired at our option or replaced without charge. The Applicable Warranty period for the New PHOENIX Laminators shall be one year on parts and three months on labor and rollers from date of purchase.

After three months and for up to one year after the date of purchase, the manufacturer will complete Warranty repair labor at no charge provided the labor is completed at one of our Authorized Locations. It is the responsibility of the original consumer purchaser to return the PHOENIX laminator to our Authorized Locations. For a list of Authorized Repair Locations, please contact your Dealer.

All Warranty repairs must be approved in advance by Technical Service. If returning the PHOENIX for approved Warranty repairs, it is the consumer's responsibility to insure the machine is packaged in its original packing to minimize the chances of any shipping damage. Shipping damage is not covered under this Warranty and is a matter between the consumer and the freight company used to transport this back to the authorized repair center. If you need proper packaging, your Dealer can supply such packaging at a nominal cost.

This Warranty extends to and is enforceable by only the original consumer purchaser, and only for the period (during the applicable term), which the product remains in the possession of the original consumer purchaser.

"Original consumer purchaser" means the person who first purchased the product covered by this warranty. It does not apply if it is found that at any time the equipment has not been used for its intended purpose.

Any unauthorized changes or modifications to this unit without our prior written approval will void the user's Warranty.

The applicable warranty period for Demo Equipment shall vary, not exceeding the maximum warranty period stated herein. All Demo Equipment comes with a specific warranty, which will be stated at the time of purchase. If warranty period is not detailed in writing, there is no remaining warranty. Please ask your dealer or sales representative for details.

Used Equipment or non-Demo equipment is sold on an "AS IS" basis with No Warranty. For more information regarding this warranty, please contact your distributor.

The information contained in this document is subject to change without notice.

The Manufacturer assumes no responsibility for any errors that may appear in the Owner's Manual. Nor does it make expressed or implied warranty of any kind with regard to this material including, but not limited to, the implied warranties of merchantability and fitness for a particular purpose.

The Manufacturer shall not be liable for incidental or consequential damages in connection with, or arising out of the furnishing, performance, or use of this document and the program material, which it describes.

Phoenix Authorized Repair Center

Midwest Distribution Center
13878 Parks Steed Drive
Earth City, MO. 63045
314-739-4400